

# INSTRUCTION MANUAL

# TALBOYS

**Advanced 1000RS Rocking Shaker**  
**Advanced 1000WS Waving Shaker**



## TABLE OF CONTENTS

Package Contents	1
Warranty	1
Installation	2
Maintenance & Servicing	2
Environmental Conditions	2
Safety Instructions	3
Standards & Regulations	3
Control Panel	4
Advanced 1000RS Rocking Shaker	5
Advanced 1000WS Waving Shaker	6
Operating Instructions	7-8
Troubleshooting	8
Replacement Parts	9-10
Accessories	11

## PACKAGE CONTENTS

---

Advanced 1000RS Rocking Shaker or Advanced 1000WS Waving Shaker  
Non-skid rubber mat  
92" (234cm) detachable power cord  
Instruction manual  
Warranty card

## WARRANTY

---

Manufacturer warrants this product to be free from defects in material and workmanship when used under normal conditions for two (2) years. Please complete and return the enclosed warranty card. For your reference, make a note of the serial number, date of purchase and supplier here.

Serial No.: \_\_\_\_\_ Date of Purchase: \_\_\_\_\_

Supplier: \_\_\_\_\_

## INSTALLATION

---

Upon receiving the Talboys Rocking/Waving Shaker, check to ensure that no damage has occurred during shipment. It is important that any damage that occurred in transport is detected at the time of unpacking. If you do find such damage the carrier must be notified immediately.

After unpacking, place the Rocking/Waving Shaker on a level bench or table, away from explosive vapors. Ensure that the surface on which the unit is placed will withstand typical heat produced by the unit. Always place the unit on a sturdy work surface.

The Rocking/Waving Shaker is supplied with a power cord that is inserted into the IEC connector on the back of the unit first, then it can be plugged into a properly grounded outlet. The 120V unit plugs into a 120 volt, 50/60 Hz source. The 230V unit plugs into a 230 volt, 50/60 Hz source.

## MAINTENANCE & SERVICING

---

The Rocking/Waving Shaker is built for long, trouble-free, dependable service. No lubrication or other technical user maintenance is required. However at least every three (3) months you should:

- Unplug the unit.
- Remove any accumulated dirt from the base and tray.
- Check all accessible items to make sure they are properly tightened.

The unit should be given the care normally required for any electrical appliance. Avoid wetting or unnecessary exposure to fumes. Spills should be removed promptly. **DO NOT** use a cleaning agent or solvent on the front panel which is abrasive or harmful to plastics, nor one which is flammable. Always ensure the power is disconnected from the unit prior to any cleaning. If the unit ever requires service, contact your Talboys representative.

## ENVIRONMENTAL CONDITIONS

---

**Operating Conditions:** Indoor use only.

\* For use in CO<sub>2</sub> environments, incubators or cold rooms.

\* Temperature: -10 to 60°C (14 to 140°F).

Humidity: maximum 80% relative humidity, non-condensing

Altitude: 0 to 6,562 ft (2000 M) above sea level

**Non-Operating Storage:**

\* Temperature: -20 to 65°C (-4 to 149°F)

Humidity: maximum 80% relative humidity, non-condensing

Installation Category II and Pollution Degree 2 in accordance with IEC 664.

\* **Avoid cold starts:** Unit is not designed to start after being in a cold room environment. Bring unit into cold room from a room temperature environment, operate and remove unit from cold room as soon as operation is complete.

## SAFETY INSTRUCTIONS

---

Please read the entire instruction manual before operating the Rocking/Waving Shaker.



**WARNING! DO NOT** use the Rocking/Waving Shaker in a hazardous atmosphere or with hazardous materials for which the unit was not designed. Also, the user should be aware that the protection provided by the equipment may be impaired if used with accessories not provided or recommended by the manufacturer, or used in a manner not specified by the manufacturer.

Always operate unit on a level surface for best performance and maximum safety.

**DO NOT** lift unit by the tray.



**CAUTION!** To avoid electrical shock, completely cut off power to the unit by disconnecting the power cord from the unit or unplug from the wall outlet. Disconnect unit from the power supply prior to maintenance and servicing.

Spills should be removed promptly. Biohazard spills should be cleaned up using approved laboratory procedures. Solvent spills are a fire hazard. Stop the unit immediately, and **DO NOT** operate until clean up is complete and vapors have dissipated (motor brushes arc and may ignite flammable vapors). **DO NOT** immerse the unit for cleaning.

**DO NOT** operate the unit if it shows signs of electrical or mechanical damage.



Earth Ground - Protective Conductor Terminal



Alternating Current

## STANDARDS & REGULATIONS

---

Henry Troemner LLC hereby declares under its sole responsibility that the construction of this product conforms in accordance with the following standards:

### Safety standards:

IEC 61010-1 Safety requirements for electrical equipment for measurement, control and laboratory use. Part I: General Requirements.  
IEC 61010-2-051 Part II: Particular requirements for laboratory equipment for mixing and stirring.

UL Std. No. 61010-1  
CSA/CAN C22.2 No. 0-M91  
CSA/CAN C22.2 No. 61010-1-04

### EMC standards:

FCC-B	EN55022-B
EN6100-3-3	EN6100-4-5
EN61000-4-2	EN61000-4-3
EN61000-4-4	EN61000-4-6
EN61000-4-11	EN61326-1 Class A

### Associated EU guidelines:

EMC directive 2004/108/EC  
LVD directive 2006/95/EC  
Machine directive 98/37/EC

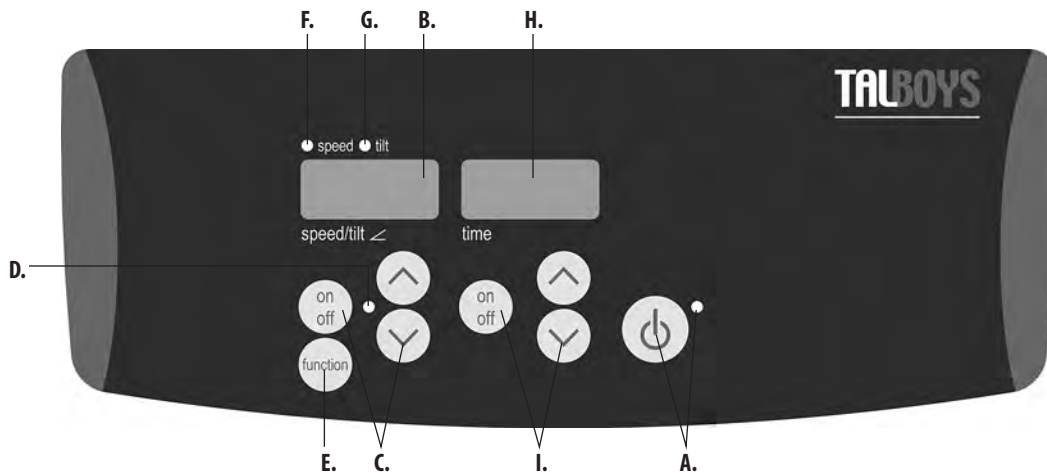

## CONTROL PANEL

The front panel of the Rocking/Waving Shaker contains all the controls and displays needed to operate the unit.

**A. Standby button/standby indicator light:** The standby indicator light will illuminate when the unit is plugged in. The unit will be in standby mode. Press the standby button to activate the speed/tilt angle and time functions. The standby indicator light will shut off and the speed/tilt angle display and time display will illuminate. Press the standby button again and the unit will once again be in standby mode.

**B. Speed/tilt angle display:** Displays the speed and tilt angle of the unit. **C.** Up/down arrows for set-point control. On/off button starts/stops the rocking/waving function. **D.** The speed/tilt angle indicator light will be illuminated when the unit is rocking/waving.

**E. Function button:** Press to choose the function you are setting: speed or tilt.

**F. Speed indicator light:** Illuminates when the speed is displayed.

**G. Tilt indicator light:** Illuminates when the tilt angle is displayed.

**H. Time display:** Displays accumulated time (continuous mode) or how much time is remaining (timed mode). The display range is from 0 to 9,999 minutes in one (1) second increments. The display will indicate minutes and seconds until the timer reaches 99 minutes and 59 seconds (99:59), then the display will automatically display minutes up to 9,999.

**I.** Up/down arrows for set-point control. On/off button starts/stops the time function

## ADVANCED 1000RS ROCKING SHAKER SPECIFICATIONS



**Overall dimensions (L x W x H):** 17 x 11 x 5" (43.2 x 27.9 x 12.7cm)

**Tray dimensions (L x W):** 12.75 x 10" (32.4 x 25.4cm)

**Electrical (50/60 Hz):** 120 volts AC, 5 amps, 25 watts  
230 volts AC, 5 amps, 25 watts

**Fuses:** 5mm x 20mm, 5 amp quick acting

**Speed range:** 1 to 50rpm \*

**Speed accuracy:**  $\pm 1$ rpm

**Tilt angle:** 0 to 15° \*

**Timer:** 1 second to 9999 minutes  
(increased in 1 second increments)

**Maximum weight capacity:** 10lbs (4.5kg) \*\*

**Controls:** see page 4

**Tray material:** aluminum

**Ship weight:** 15.5lbs (7kg)

\* Maximum speed/tilt angle may vary with heavy or unbalanced loads.

\*\* Centered on tray.

## ADVANCED 1000WS WAVING SHAKER SPECIFICATIONS

<b>Overall dimensions (L x W x H):</b>	17 x 11 x 6" (43.2 x 27.9 x 15.2cm)
<b>Tray dimensions (L x W):</b>	11.75 x 8.75" (29.9 x 22.2cm)
<b>Electrical (50/60 Hz):</b>	120 volts AC, 5 amps, 25 watts 230 volts AC, 5 amps, 25 watts
<b>Fuses:</b>	5mm x 20mm, 5 amp quick acting
<b>Speed range:</b>	1 to 30rpm *
<b>Speed accuracy:</b>	±1rpm
<b>Tilt angle:</b>	0 to 20° *
<b>Timer:</b>	1 second to 9999 minutes (increased in 1 second increments)
<b>Maximum weight capacity:</b>	5lbs (2.3kg) **
<b>Controls:</b>	see page 4
<b>Tray material:</b>	aluminum
<b>Ship weight:</b>	16lbs (7.3kg)

\* Maximum speed/tilt angle may vary with heavy or unbalanced loads.

\*\* Centered on tray.



Advanced 1000WS Waving Shaker with glassware

## ADVANCED ROCKING/WAVING SHAKER OPERATING INSTRUCTIONS

The Rocking/Waving Shakers have been designed for the speed/tilt angle and time functions to work independently of one another. The speed/tilt angle can be reset without resetting the timer and the timer can be stopped and started without interrupting the rocking/waving function.

### 1. Getting ready:

- a. Plug the power cord into a properly grounded outlet. The standby indicator light will illuminate, verifying power to the unit. Manually move the tray to a near horizontal "home" position before powering unit.
- b. Press the standby button to move the unit from standby mode. The standby indicator light will turn off and the speed/tilt angle and time displays will illuminate, displaying the previously used settings.



### 2. Setting tilt angle: Electronic tilt enables the user to adjust the angle of tray movement while the unit is rocking/waving or while the unit is stopped.

- a. Press the function button below the speed/tilt angle display until the tilt indicator light illuminates. You are now ready to set the tilt angle.
- b. Press the up/down arrows below the speed/tilt angle display until you reach the desired angle. When you release the button, the display will blink off and then on indicating the new set angle has been accepted. The unit will complete one rotation at the previously set angle, then smoothly change to the newly programmed angle. The tilt indicator light will flash until the transition to the new tilt angle is complete.

### 3. Setting speed:

- a. Press the function button below the speed/tilt angle display until the speed indicator light illuminates. You are now ready to set the speed.
- b. Press the up/down arrows below the speed/tilt angle display until you reach the desired speed. When you release the button, the display will blink off and then on indicating the new set speed has been accepted.

- c. Press the on/off button to start the rocking/waving function. The indicator light below the speed/tilt angle display will illuminate and blink until the set-point is reached. Once the set-point is reached the light will stop blinking and remain lit until rocking/waving has ceased.
- d. To stop the rocking/waving function, press the on/off button below the speed/tilt angle display. The unit will complete one full rotation then stop in the horizontal "home" position. The speed indicator light will flash until the rotation is complete. When the cycle is complete, the unit will automatically move to standby mode and the standby indicator light will illuminate.

## OPERATING TIPS

When the unit is running at slow speeds or high angles, making large changes to the tilt angle or speed may take several minutes to complete. The quickest way to make large changes is to stop the unit, change the speed or tilt angle, then restart by pressing the on/off button below the speed/tilt angle display.

### 4. Setting time to zero (0:00) and continuous mode: Accumulated time.

- a. Press and hold the on/off button below the time display. After three (3) seconds the display will indicate the previous set time.
- b. Simultaneously press both the up and down arrows, the display will indicate zero (0:00). The unit time is now set to zero (0:00) minutes. Alternately, you can use the up/down arrows to get to zero (0:00).
- c. Press the on/off button below the time display. The display will indicate accumulated time. The up/down arrows will become inactive. To stop timer, press the on/off button again. **IMPORTANT:** This will **NOT** interrupt the rocking/waving function. Press the on/off button below the speed/tilt angle display to interrupt the rocking/waving function.
- d. To reset, press and hold the on/off button below the time display. After three (3) seconds the display will indicate the previous set time, which was zero (0:00).

5. **Setting timed mode:** Programmed time.
  - a. Press the up/down arrows below the time display until you reach the desired time.
  - b. Start this function by pressing the on/off button below the time display. The unit will run for the selected time, the up/down arrows will become inactive while the timer is running. The unit will stop rocking/waving when the time display reaches zero (0:00). Four (4) audible beeps will indicate the count down function is complete. The time display will default back to the set time. To repeat for the same time, simply press the on/off button again.
  - c. To interrupt an automatic timing cycle before it is completed, press the on/off button below the time display. The time display will flash off and on to indicate the time function is on "hold". **IMPORTANT:** This will **NOT** interrupt the rocking/waving function. Press the on/off button below the speed/tilt angle display to interrupt the rocking/waving function. Restart the timer by pressing the on/off button below the time display. Unit will continue counting down to zero (0:00). When the display reaches zero (0:00), you will hear the four (4) audible beeps that indicate the count down function is complete and the rocking/waving function will cease.

#### 6. Turning unit off:

- a. To turn the unit off, press the standby button. The speed/tilt angle and time displays will be blank, the standby indicator light will illuminate. The Rocking/Waving Shaker should be kept in standby mode when not in use. To completely cut off power to the unit, disconnect the power cord from the unit or unplug from the wall outlet.

### OPERATING TIPS

As a safety feature, a built-in program will shut power off to the motor if the tray is prevented from rocking/waving, or the unit is overloaded beyond its recommended weight capacity.

Built-in memory maintains the last used speed/tilt angle and time settings during a power interruption.

### TROUBLESHOOTING

During operation, any rattling or ticking sounds may indicate a loose screw on the tray, a tray attachment or an accessory. All accessories should be sufficiently tightened in place before starting the unit.

<u>Error Code</u>	<u>Software Test</u>	<u>Cause</u>
E04	unit overloaded	maximum load exceeded

Press the standby button to clear this error. Be sure the load is within the maximum load capacity before restarting the unit. If the E04 error persists, switch the unit off and contact your Talboys representative for repairs.

<u>Error Code</u>	<u>Software Test</u>	<u>Cause</u>
E03	drive system failure	ceased motor drive belt broken mechanical obstruction

In the event of someone/something inadvertently touching the tray while the unit is running, the unit will display an E03 error message, and automatically go to the horizontal "home" position and restart.

In the event of a mechanical obstruction, the unit will attempt to auto "home" and restart four (4) times and then stop running, displaying an E03 error message. Press the standby button to clear this error and remove the mechanical obstruction.

If the E03 error persists the reason may be a ceased motor or broken drive belt and should **NOT** be addressed by the end user. Switch the unit off and contact your Talboys representative for repairs.

## ADVANCED 1000RS ROCKING SHAKER REPLACEMENT PARTS

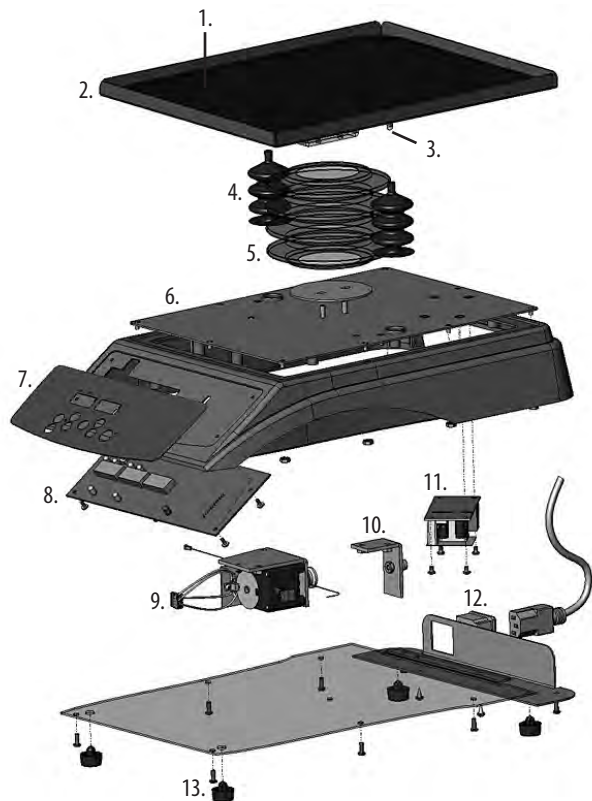

### DESCRIPTION

1. Non-skid rubber mat
2. Tray assembly
3. Spring
4. Bellows rocker
5. Bellows center
6. Platform tray
7. Front panel
8. Circuit board
9. Motor assembly
10. Idler assembly
11. Power supply
12. Power entry module 120V  
230V
- Fuse
13. Feet

### PART NUMBER

		580076-00
		880523-00
		180060-00
		280436-00
		280434-00
		280405-00
		385724-00
		380735-00
		880533-00
		880531-00
		386453-00
		380755-00
		380237-00
		380238-00
		149023-00
Detachable 92" (234cm) power cord:	120V	330100-00
	EURO	330101-00
	UK	330102-00
	SWISS	330103-00

## ADVANCED 100WS WAVING SHAKER REPLACEMENT PARTS

### DESCRIPTION

- 1. Non-skid rubber mat
- 2. Tray assembly
- 3. Spring
- 4. Bellows waver
- 5. Bellows center
- 6. Platform tray
- 7. Front panel
- 8. Circuit board
- 9. Motor assembly
- 10. Idler assembly
- 11. Power supply
- 12. Power entry module 120V  
230V
- Fuse
- 13. Feet

### PART NUMBER

Detachable 92" (234cm) power cord:	120V	330100-00
	EURO	330101-00
	UK	330102-00
	SWISS	330103-00

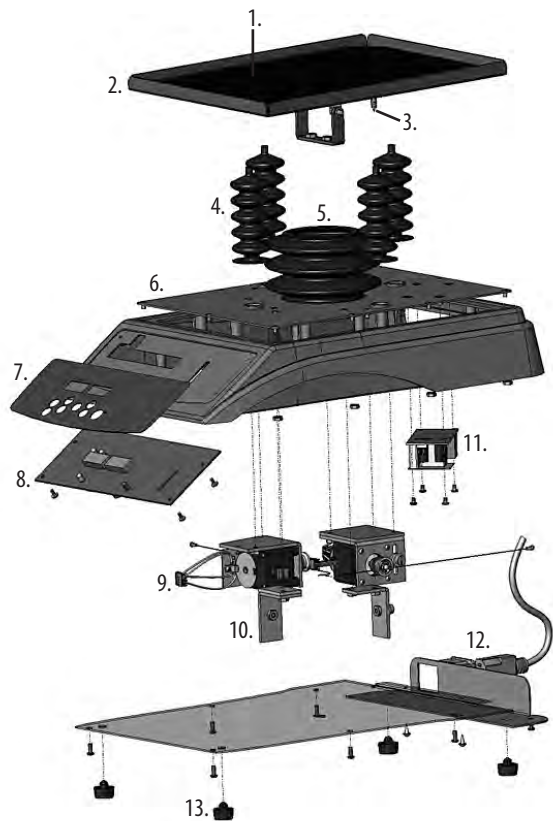

**DIMPLED MAT**

Designed to hold centrifuge tubes, vials, culture tubes, and micro-tubes securely in place. Mat can be easily removed for cleaning and transporting tubes from bench to tray.

<b>Description</b>	<b>Dimensions (L x W)</b>	<b>Part Number</b>
Dimpled Mat, Rocking Shaker	12.75 x 10" (32.4 x 25.4cm)	980535
Dimpled Mat, Waving Shaker	11.75 x 8.75" (29.9 x 22.2cm)	980542

**STACKING TRAY**

Easily attaches to the lower included tray to add a second tier for higher capacity applications. Second tier tray mounts 3.5" (8.9cm) above the lower tray.

<b>Description</b>	<b>Part Number</b>
Stacking Tray, Rocking Shaker	980534
Stacking Tray, Waving Shaker	980541



Manufactured by:

**TALBOYS**

201 Wolf Drive • PO Box 87 • Thorofare, NJ 08086

Phone: 1-888-TALBOYS • Fax: 856-686-1601

E-mail: [info@talboys.com](mailto:info@talboys.com) • [www.talboys.com](http://www.talboys.com)

715079-00 (REV 4 - 6/10)